

# ***56cm Gasoline Tiller***

**IMPORTANT! PLEASE READ THESE INSTRUCTIONS CAREFULLY. NOTE ALL SAFETY INSTRUCTIONS AND WARNINGS. USE THE PRODUCT CORRECTLY AND WITH CARE FOR THE PURPOSE FOR WHICH IT IS INTENDED. FAILURE TO FOLLOW THESE INSTRUCTIONS MAY CAUSE DAMAGE TO PROPERTY AND/OR PERSONAL INJURY.**

**PLEASE KEEP THESE INSTRUCTIONS SAFE AND AVAILABLE FOR FUTURE REFERENCE.**

This manual contains information on operation and maintenance of the tiller, which is based on the most recent product information available at the time of approval for printing. We reserve the right to make amendments without advance notice.

This manual should be considered a permanent part of the tiller and remain with it at all times.

Pay special attention to statements preceded by the following words.



**DANGER** indicates a hazard with a high level of risk which, if not avoided, will result in death or serious injury.



**WARNING** indicates a hazard with a medium level of risk which, if not avoided, could result in death or serious injury.



**CAUTION** indicates a hazard with a low level of risk which, if not avoided, could result in minor or moderate injury.









If a problem arises, or you have any questions about the tiller, please consult an authorised dealer.







**WARNING:** The tiller is designed to give safe and dependable service if operated according to instructions. Read and understand the Owner's Manual before operating the tiller. Failure to do so could result in personal injury or equipment damage.

# ***SAFETY INSTRUCTIONS***

## **Warning Symbols**

For the safety of yourself and others, please pay special attention to these precautions.

	<p>This tiller is designed to give safe and dependable service if operated according to the instructions. Read and understand the Owner's Manual before operating the tiller. Failure to do so could result in personal injury or equipment damage.</p>
	<p>Exhaust gas Contains poisonous carbon monoxide. Never run the tiller in enclosed areas. Be sure to provide adequate ventilation. When installing, ventilated protection is to be observed.</p>
	<p>The rotating parts are sharp and run at high speed. Accidental contact can cause serious injury. Keep your hands and feet away from the parts while the engine is running. Stop the engine and disengage the tines clutch before inspection or maintenance of the tines. Disconnect the spark plug cap to prevent any possibility of accidental starting. Wear heavy gloves to protect your hands from the tines when clearing, inspecting or replacing the tines.</p>
	<p>Read instruction manual and safety instructions before starting up and pay attention!</p>
	<p>Wear ear protection!</p>
	<p>Wear safety goggles!</p>
	<p>Wear work gloves!</p>
	<p>Wear robust footwear when using the device!</p>

	Open fires forbidden!
	Attention! Do not touch rotating parts. There is serious risk of injury!
	Do not remove or modify protection and safety devices!
	Attention! Hot components - Do not touch!
	Risk of catapulted parts if the engine is running. Be sure to keep a safe distance.
	Keep bystanders away from the device!

## Safety

### WARNING! Training

- Read the instructions carefully. Be familiar with the controls and the proper use of the equipment.
- Never allow children or people unfamiliar with these instructions to use the machine. Local regulations can restrict the age of the operator.
- Never work while people, especially children, or pets are nearby;

Keep in mind that the operator or user is responsible for accidents or hazards occurring to other people or their property.

### DANGER! Preparation

- While working, always wear substantial footwear and long trousers. Do not operate the equipment when barefoot or wearing open sandals.
- Thoroughly inspect the area where the equipment is to be used and remove all objects which can be thrown up by the machine.
- WARNING - Petrol is highly flammable:
  - Store fuel in containers specifically designed for this purpose.
  - Refuel outdoors only and do not smoke while refueling.
  - Add fuel before starting the engine. Never remove the cap of the fuel tank or add petrol while the engine is running or when the engine is hot.

- If petrol is spilled, do not attempt to start the engine but move the machine away from the area of spillage and avoid creating any source of ignition until petrol vapors have dissipated.
  - Replace all fuel tank and container caps securely.
- d. Replace faulty silencers.
  - e. Before using, always visually inspect to see that the tools are not worn out or damaged. Replace worn out or damaged elements and bolts in set to preserve balance.

### **DANGER! Operation**

- a. Do not operate the engine in a confined space where dangerous carbon monoxide fumes can collect.
- b. Work only in daylight or in good artificial light.
- c. Always be sure of your footing on slopes.
- d. Walk, never run with the machine.
- e. For wheeled rotary machines, work across the slopes, never up and down.
- f. Exercise extreme caution when changing direction on slopes.
- g. Do not work on excessively steep slopes.
- h. Use extreme caution when reversing or pulling the machine towards you.
- i. Do not change the engine governor settings or over-speed the engine.
- j. Start the engine carefully according to manufacturer instructions and with feet well away from the tool(s).
- k. Do not put your hands or feet near or under rotating parts.
- l. Never pick up or carry a machine while the engine is running.
- m. Stop the engine:
  - Whenever you leave the machine.
  - Before refueling.
- n. Reduce the throttle setting during engine shut down and, if the engine is provided with a shut-off valve, turn the fuel off at the conclusion of working.

### **WARNING! Maintenance and storage**

- a. Keep all nuts, bolts and screws tight to ensure the equipment is in safe working condition.
- b. Never store the equipment with petrol in the tank inside a building where fumes can reach an open flame or spark.
- c. Allow the engine to cool before storing in any enclosure.
- d. To reduce the fire hazard, keep the engine, silencer, battery compartment and petrol storage area free of vegetative material and excessive grease.
- e. Replace worn or damaged parts for safety.
- f. If the fuel tank has to be drained, this shall be done outdoors.

## **Operator Responsibility**

- Keep the tiller in good operating condition. Operating a tiller in poor or questionable condition could result in serious injury.
- Be sure all safety devices are in working order and warning labels are in place. These items are installed for your safety.
- Be sure the safety covers (Fan cover, recoil starter cover ) are in place.
- Know how to stop the engine and tines quickly in case of emergency. Understand the use of all controls.
- Keep a firm hold on the handlebars, they may tend to lift during clutch engagement.
- Don't allow anyone without proper training to operate this tiller to avoid injury.
- Wear sturdy, full-coverage footwear. Operating this tiller on barefoot or with open toe shoes or sandals increase your risk of injury.
- Dress sensibly. Loose clothing may be caught by moving parts, increasing your risk of injury.
- Be alert, operating this tiller when you are tired, ill or under the influence of alcohol or drugs may result in serious injury.
- Keep all persons and pets away from the tilling area.
- Be sure drag bar is in place and properly adjusted.

## **Children Safety**

- Keep children indoors and supervised at all times while outdoor power equipment is being used nearby, as young children move quickly and are attracted especially by the tiller and tilling activity.
- Never assume children will remain where you last see them. Be alert and turn the tiller off if children enter the operation area.
- Children should not be allowed to operate the tiller even under adult supervision.

## **Thrown Object Hazard**

- Objects hit by the rotating tines can be thrown from the tiller with great force and may cause severe injury. Before tilling, clear the tilling area of sticks, large stones, wire, glass, etc.
- Till only in daylight.
- Pieces thrown from worn or damaged tines can cause serious injury. Always inspect the tines before using the tiller.

## **Fire and Burn Hazard**

- Gasoline is extremely flammable and gasoline vapor is explosive.
- Take extreme care when handling gasoline. Keep gasoline out of reach of children.
- Refuel in a well-ventilated area with the engine stopped.
- Allow the engine to cool down before refueling. Fuel vapor or spilled fuel may be ignited.
- The engine and exhaust system become very hot during operation and remain hot for a while after stopping.
- Touching the hot engine components can cause burn injuries and can ignite some materials.
- Avoid touching a hot engine or exhaust system.
- Allow the engine to cool down before performing maintenance or storing the tiller indoors.

### **Carbon Monoxide Poisoning Hazard**

- Exhaust gas contain poisonous carbon monoxide, a colorless and odorless gas. Breathing exhaust gas can cause loss of consciousness, even lead to death.
- If you run the engine in an area that is confined or even partially enclosed, the air you breathe could contain a dangerous amount of exhaust gas. To keep exhaust gas from building-up, provide adequate ventilation.

### **Operation on Slope**

- When tilling on slopes, keep less than half a tank of fuel to minimize fuel spillage.
- Till across the slope (at equally spaced intervals) rather than up and down.
- Be very careful when changing the direction of the tiller on a slope.
- Do not use the tiller on a slope of more than 10°.
- The maximum safe grade angle shown is for reference purpose only and should be determined according to the type of the tool before starting the engine, ensure that the tiller is not damaged and in good condition. For the safety of yourself and others, exercise extreme care when using the tiller up or down hills.

### **Ground condition**

- Adjust rotating depth according to the condition of the ground. Hoe hard ground in progressive stages.
- Do not work on soggy ground; lumps of earth can be caught by the hoeing assembly and thrown out. If foreign bodies, e.g. stones, are encountered by the hoeing device, stop the machine, switch it off and check it for damage.
- Do not work on any surfaces below which gas or power lines, or similar, are located.
- Do not work close to trees otherwise the machine may cut through the roots.

## ***PACK CONTENTS***

When you open your packaging, first remove all items and check there are no parts damaged or missing. If you find anything wrong, do not operate the product until the parts have been replaced or the fault has been rectified. Failure to do so could result in serious injury.

### **IMPORTANT INFORMATION**

**NOTE:** This product is a 4 stroke engine powered Tiller.

The engine **MUST** be filled with recommend SAE 10W/30 BEFORE starting. Fresh unleaded fuel must be used in this unit.

**DO NOT use Ethanol based fuels. DO NOT mix oil with fuel.**

**NOTE:** Inexperienced or first time users pay particular attention to the operation of the Tiller, including details of starting and stopping the tiller and correct use.

### **Contents of carton**

- 1x Tiller main body
- 1x Handle bar
- 2x Mud fender
- 1x Drag bar
- 1x Drag bar hairpin
- 2x Blade assembly
- 1x Handle bar adjuster
- 1x Handle bar mounting cover
- 2x Cable clips
- 6x Mud fender assembly (M8x16 bolt+ $\Phi$ 8 washer+ M8 nut)
- 4x Mud fender support M6x16 bolt and M6 nut
- 1x M5x20 bolt
- 2x ST4.8x16 bolt
- 2x  $\Phi$ 8x40 wheel locking pin
- 2x Wheel hairpin
- 1x Locking pin for connecting bar
- 1x Hairpin for connecting bar

## COMPONENT IDENTIFICATION

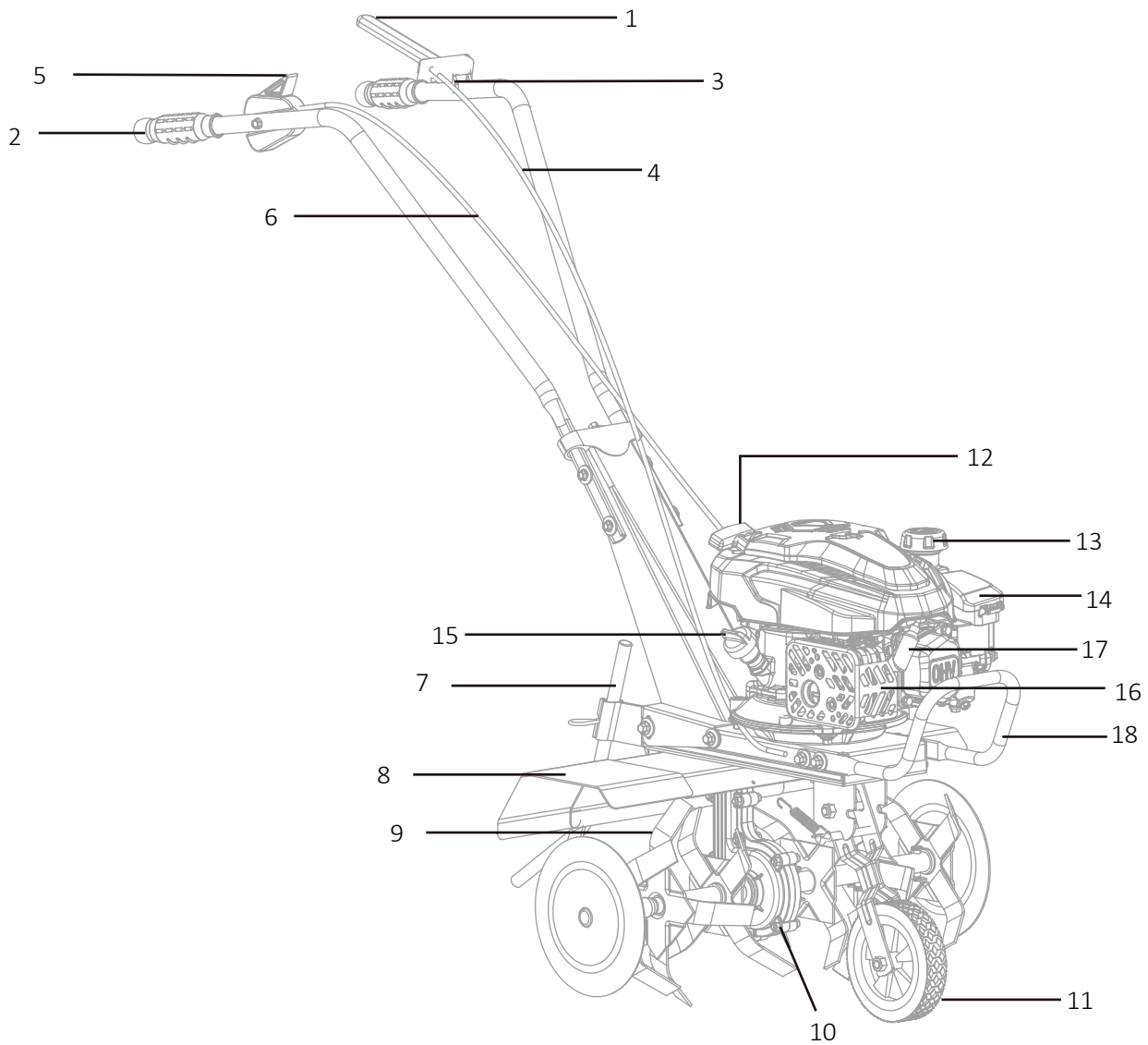

- |                                  |                    |
|----------------------------------|--------------------|
| 1. Tooling Clutch                | 11. Front Wheel    |
| 2. Handle                        | 12. Recoil Starter |
| 3. Lock Clutch Lever             | 13. Fuel Tank Cap  |
| 4. Clutch Cable                  | 14. Air Filter     |
| 5. Engine Speed Adjustment       | 15. Oil Dipstick   |
| 6. Engine speed adjustment cable | 16. Muffler        |
| 7. Drag Bar                      | 17. Spark Plug     |
| 8. Mud Fender                    | 18. Handle         |
| 9. Blade Assembly                | 19. Knife Guard    |
| 10. Gear Box                     |                    |

## ASSEMBLY

**WARNING!** Stop the engine and unplug the spark plug before any repairs or maintenance operations.

**WARNING!** DO NOT attempt to start this mower without the mower first being FULLY assembled.

**WARNING!** DO NOT attempt to start this mower without first adding SAE 10W/30 engine oil to the engine.

Before assembling, please take all parts out from the package and place them on the ground, carefully check all components.

### Lift Front Wheel

Pull the front wheel downward so that the front wheel can rotate freely, then lift the front wheel bracket to a proper position and the front wheel bracket will be fixed automatically by the spring. The tiller can stand with no other support.

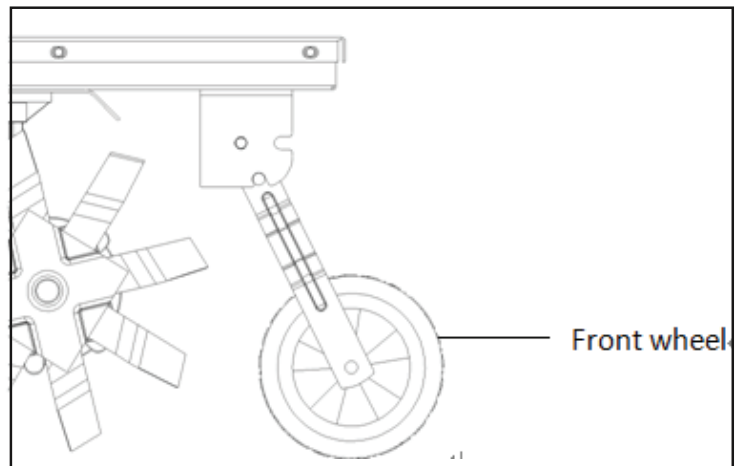

### Attaching the handle bar

Attach the handle bar to the handle bar support properly to align the assembly holes and then fix with M8\*45 bolt.



### Drag bar

First attach the drag bar (7) to the drag bar holder, choose a proper height and then lock the drag bar with R-type locking pin.

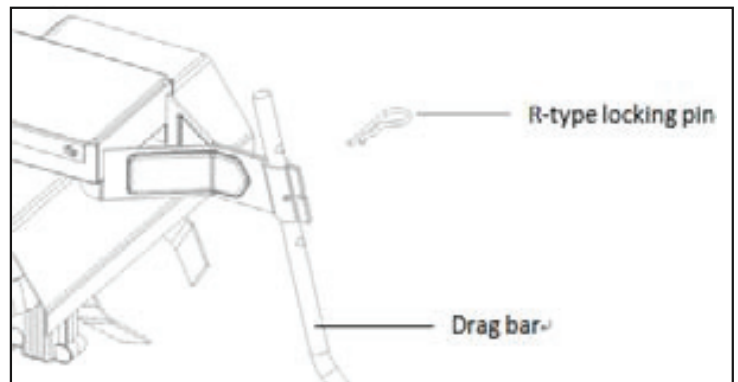

## Rotary knife

Attach the blade protection disc, rotary knife, secondary rotary knife and disc to the drive shaft in the specified order. Then secure the rotary knife assembly with the listed pins and R-type locking pins.

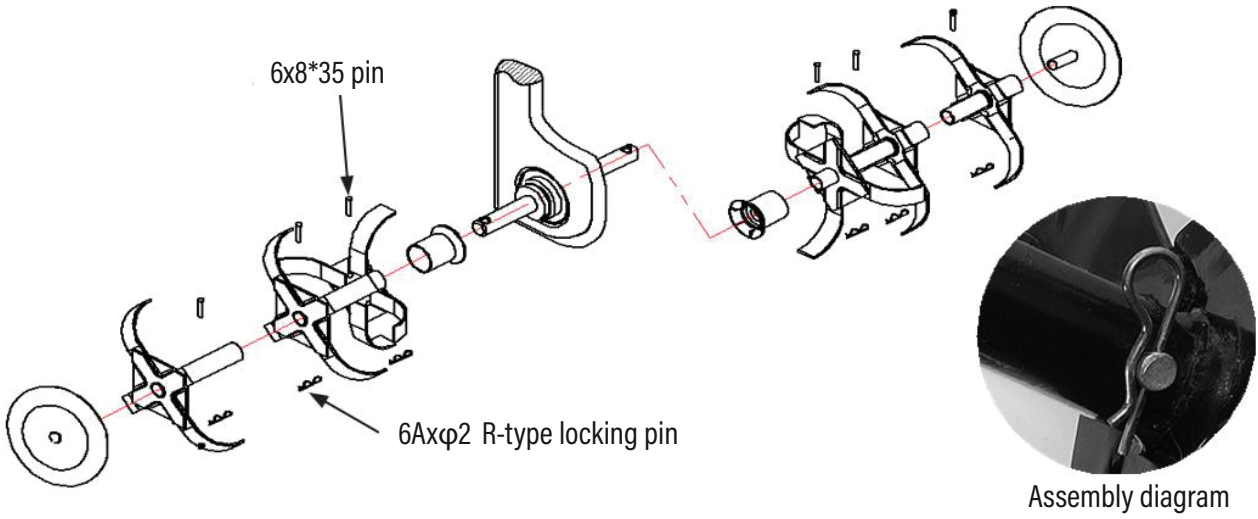

## PRE-OPERATION CHECK

Please attention to check all the components are good and controls are functional before each use.

### Engine oil

**CAUTION:** Running the engine with low oil level will cause serious engine damage.

1. Wipe the dipstick.
2. Put the dipstick into the oil filler neck, and screw it in.
3. If the level is low, fill the recommended oil to the middle of the oil dipstick.

Use high-detergent, premium quality 4-stroke engine oil, certified to meet or exceed U.S. automobile manufacturer's requirement for API Service Classification SG, SF.

**CAUTION:** Using non-detergent oil or 2-stroke engine oil could shorten the engine's service life.

SAE 10w-30 is recommended for general, all temperature use. Other viscosities shown in the following chart might be used when the average temperature in your area is within the indicated range.

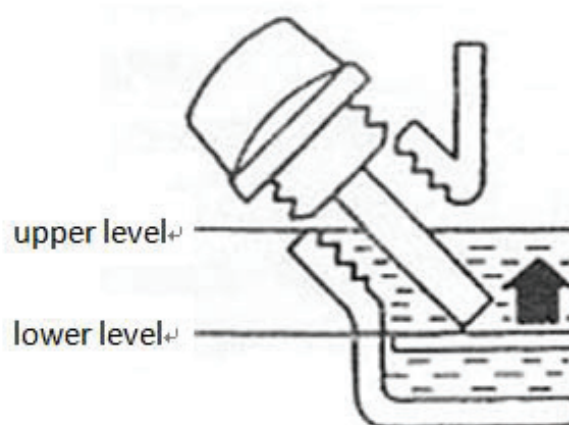
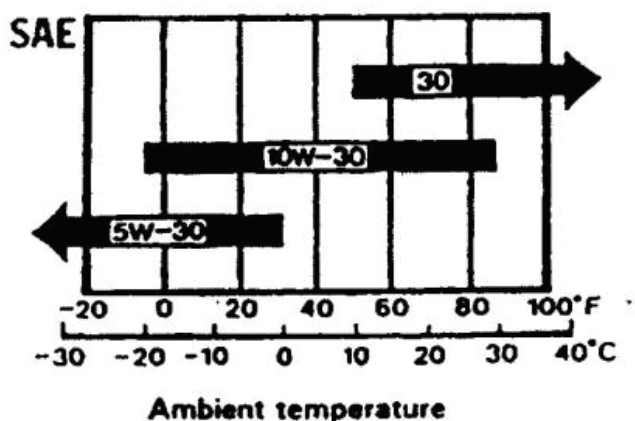

### Air Filter

Check air filter for dirt or obstruction of elements

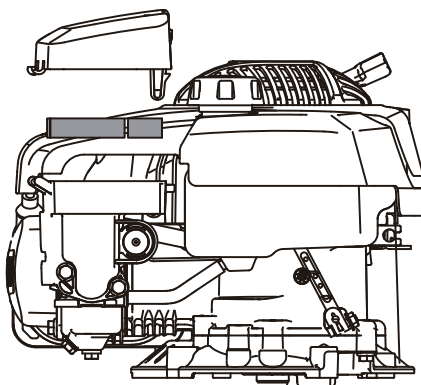

## **Fuel**

Use automotive gasoline (Unleaded is preferred to minimize combustion chamber deposits.)

Never use an oil/gasoline mixture or dirty gasoline.  
Avoid dirt, dust or water from getting into the fuel tank.

**CAUTION:** Do not fill over the red level line.

### **WARNING!**

- Gasoline is extremely flammable and is explosive under certain conditions.
- Refuel in a well-ventilated area with the engine stopped. Do not smoke or allow flames or sparks in the area where the engine is refueled or the gasoline is stored.
- Do not overfill the fuel tank (there should be no fuel in the filler neck). After refueling make sure the tank cap is closed properly and securely.
- Be careful not to spill fuel when refueling. Spilled fuel or fuel vapor may be ignited. If any fuel is spilled, make sure the area is dry before starting the engine.
- Avoid repeated or prolonged contact with skin or breathing of vapor.

**Fuel tank capacity: Refer to Specifications section.**

### **Tools and attachments**

To install a tool or attachment to the tiller, follow the instructions furnished with the tool or attachment. Ask your dealer for advice if you encounter with any problem or difficulty in installing a tool or attachment.

**CAUTION:** Be sure the clutch is disengaged and the shift lever is in the neutral position to prevent sudden uncontrolled movement when the engine starts. The clutch is engaged by pulling in the clutch lever and disengaged by releasing the lever.

## ***ENGINE START***

Turn the engine switch to "ON":

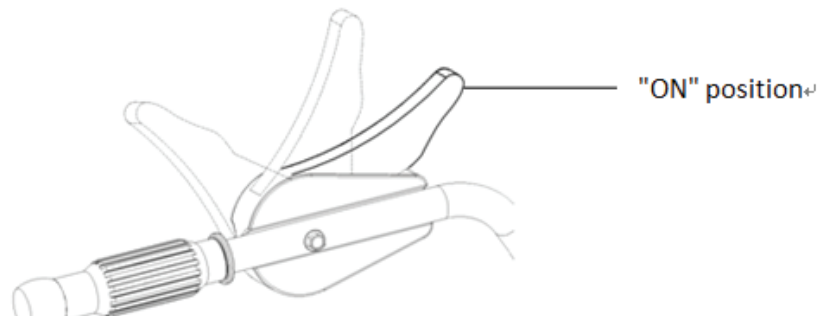

Pull the starter grip lightly until resistance is felt then pull rapidly.

**CAUTION:** Do not allow the starter grip to snap back against the engine. Return it gently to prevent damage to the starter.

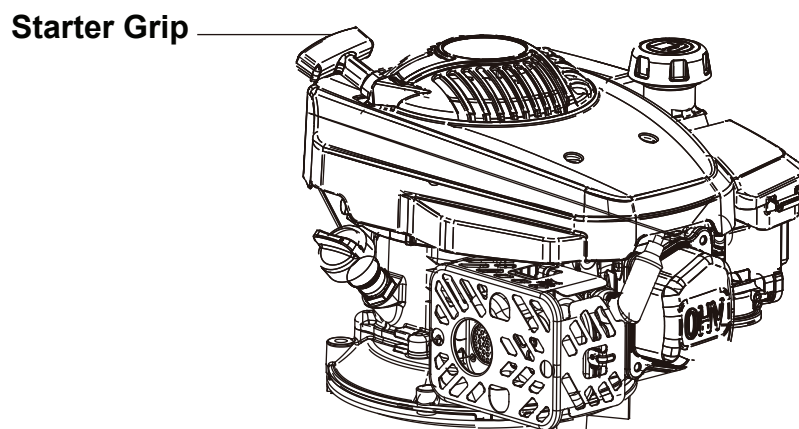

As the engine warms up, gradually open the choke.

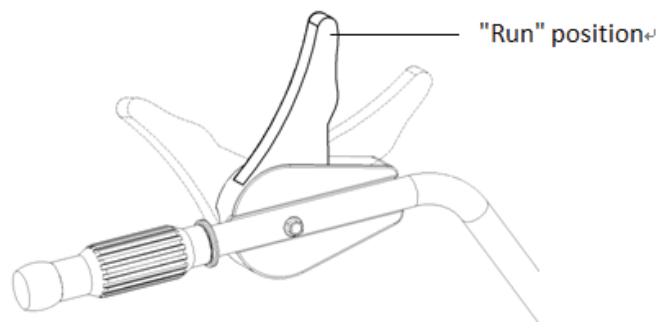

## TILLER OPERATION

### Tiller height adjustment

**CAUTION:** Before adjusting the handle bar, place the tiller on firm level ground to prevent the handle from collapsing accidentally.

To adjust the tiller height, loosen the adjuster, select the appropriate hole and tighten the adjuster.

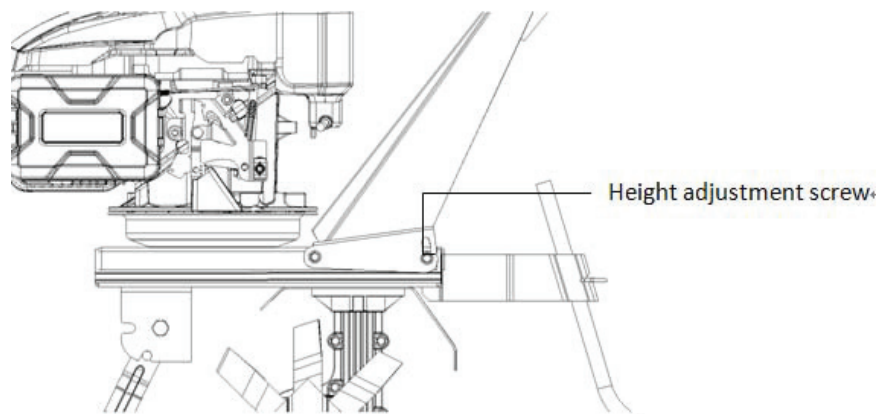

### Tilling depth adjustment

Install the hitch attachment in the hitch box with a hitch pin.

The tilling depth adjustment can be made as follows:

Remove the hitch bar locking pin, sliding the drag bar up or down as necessary.

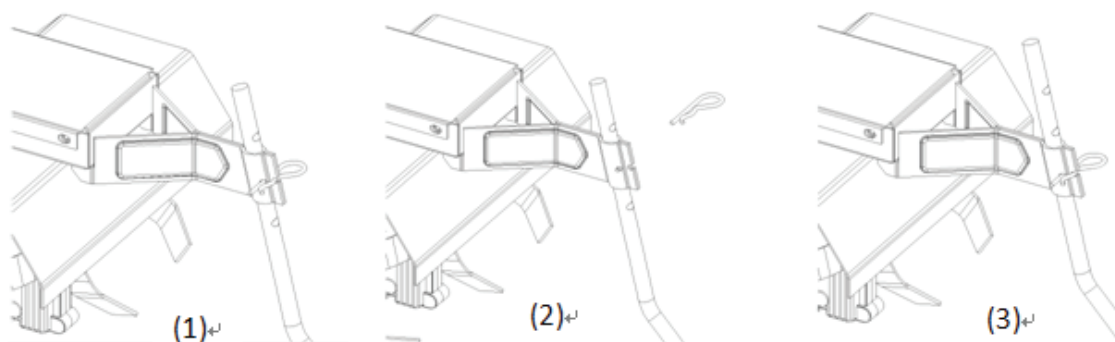

### Clutch operation

The clutch engages and disengages the power from the engine to the transmission.

When the clutch lever is squeezed the clutch is engaged and power is transmitted. Squeeze the lever, the tool will be rotated.

When the lever is released, the clutch is disengaged and power is not transmitted, release the clutch lever, the tool will be stopped.

**CAUTION:** Reduce engine rpm before operating main clutch.

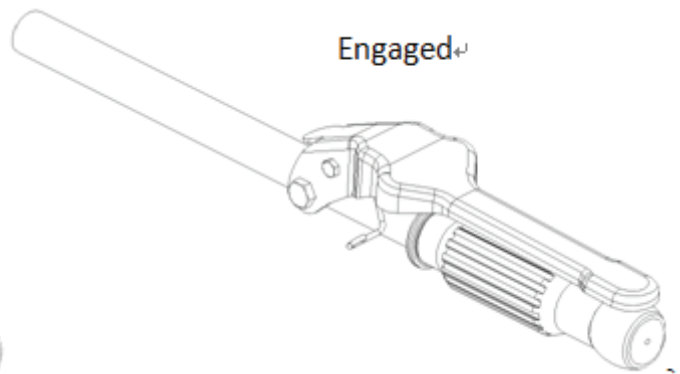
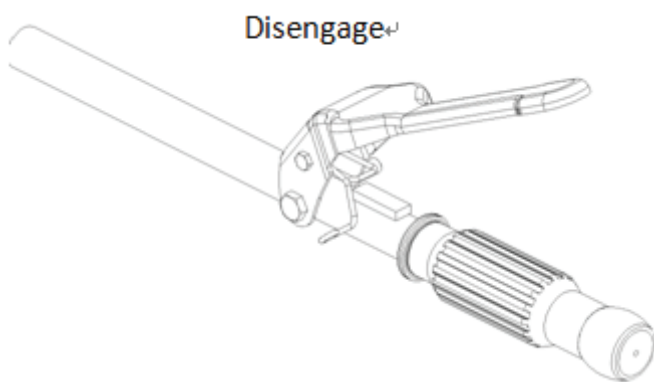

## Front wheel

Move the tiller when not in use by raising the machine by the front wheel by lifting the handlebars up.

When the tiller is used in the field, raise the wheel:

- (1) pull the front wheel downward
- (2) lift the front wheel up to proper position

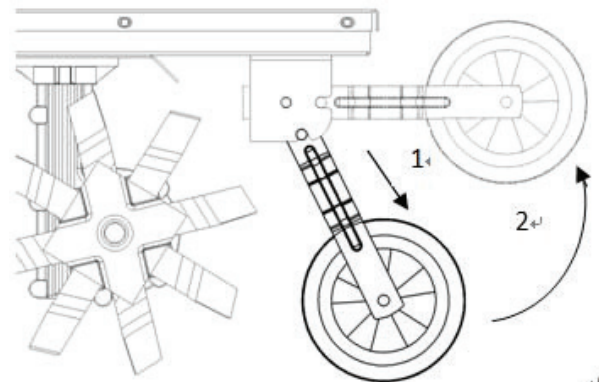

## Handling Tips

Adjust the handlebar height to a comfortable position (usually waist height is recommended)

If the machine jerks forward while tilling, press down on the handlebars; if the machine will not move forward, move the handlebars from side to side.

Turn: The proper method of negotiating a turn is to lower the handlebars to bring the weight of the tiller towards the rear and then make the turn. This will permit a turn with relative ease.

### CAUTION:

- Do not use the tiller with a rotor with diameter over 260mm.
- Operating the tiller on steep grades could cause the tiller to tip over.
- Allowing any one to operate this tiller without proper instruction may result in injury.
- Wear sturdy, full coverage footwear. Operating this tiller on bare feet, or with open toe shoes or sandals increases your risk of injury.
- Do not use the tiller at night.
- Be sure to transport the tiller from one place to another by two people, if a carrier is not available.
- When the rotor is clogged with mud, pebble etc, immediately stop the engine and clean the rotor in a safe place. Be sure to wear heavy gloves when cleaning the rotor.
- To prevent damage, check the tiller for any signs of damage or other faults each time when the tiller is used after it has been operated.

## **STOPPING**

### **In an emergency**

Turn the engine switch/chock lever to "STOP" position.

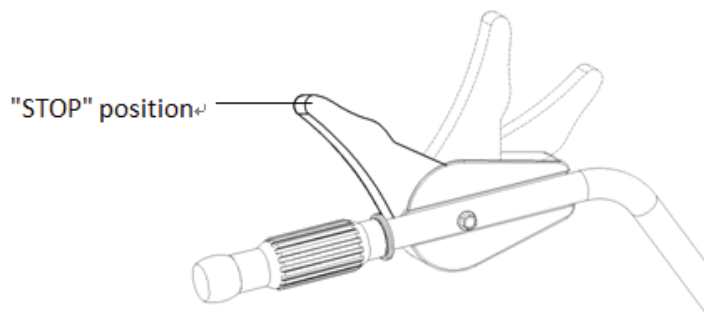

### **In normal use**

Release the clutch lever to DISENGAGED position and move chock lever to "STOP" position.

(1) Disengage the clutch

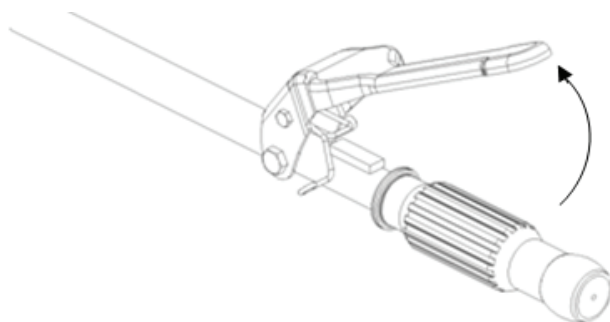

(2) Turn the chock lever to "STOP" position

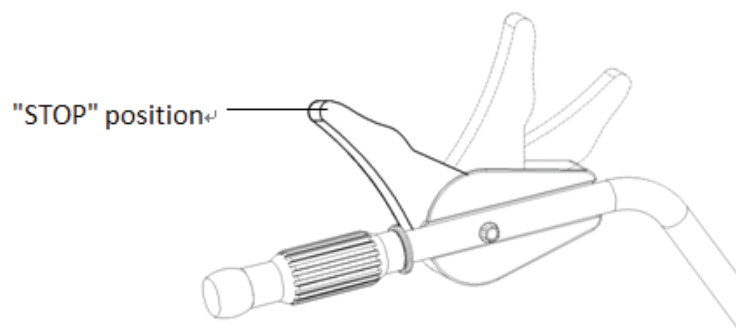

## MAINTENANCE

The purpose of the maintenance schedule is to keep the tiller in the best working condition, inspect or service as scheduled in the table below.

**WARNING** Turn off the engine before performing any maintenance. If the engine must be run, make sure the area is well-ventilated. The exhaust contains poisonous carbon monoxide gas.

**CAUTION:** Use only genuine parts or their equivalents. The use of replacement parts which are not of equivalent quality may damage the engine.

Maintenance Schedule:

		REGULAR SERVICE PERIOD				
		Daily	First month or 20 HRS	Every 3 months or 50 HRS	Every 6 months or 100 HRS	Every year or 300 HRS
ITEM						
Engine oil	Check level	X				
	Change		X		X	
Air cleaner element	Check	X				
	Clean			X		
Fuel strainer cu	clean				X	
Spark plug	Clean readjust				X	
Transmission gear oil	Check level	X				
Tappet clearance	Check readjust					X
Fuel tank and strainer	Clean					X
Clutch cable	Adjust		X		X	
Throttle cable	Adjust					X
Belt tension	Adjust		X		X	
Fuel line	Check	Every 2 years (Replace if necessary)				

NOTE: (1) Check more frequently when used in dusty areas.

(2) These items should be serviced by an authorised dealer, unless the owner has the proper tools and is mechanically qualified.

## Changing engine oil

Drain the oil while the engine is still warm to assure rapid and complete drainage

- 1) Remove the oil filler cap and drain the oil.
- 2) Refill with the recommended oil and check its level.

Oil capacity: refer to specifications chapter.

Wash your hands with soap and water after touching used oil.

**NOTE:** Please dispose of used motor oil in a manner that is compatible with the environment. We suggest you put it in a sealed container and take to your local service for reclamation. Do not throw it to the trash can or pour it on the ground.

## Air Filter Service

A dirty air filter will block air flow into the carburetor. To prevent carburetor malfunction, service the air filter regularly. Service more frequently when operating the engine in extremely dusty areas.

**WARNING!** Never use gasoline or low flash point solvents to clean the air cleaner element. A fire or explosion could result in.

**CAUTION:** Never run the engine without air cleaner, or rapid engine wear will be the result.

- 1) Remove the wing nut and the air cleaner cover. Remove the elements and separate them. Carefully check elements for holes and tears, and replace it if damaged.
- 2) Foam element: clean in warm soapy water, risen and allow to dry thoroughly or clean in high flash-point solvent and allow to dry. Dip the element in clean engine oil and squeeze out all the excess. The engine will smoke during initial start -up if too much oil is left in the foam.
- 3) Paper element: Tap the element lightly several times on a hard surface to remove excess dirt or blow compressed air through the filter from the inside out. Never try to brush the dirt off, for so doing will force dirt into the fibers.

## Fuel Strainer Cup Cleaning

**WARNING!** Gasoline is highly flammable and explosive under certain conditions. Do not smoke or allow flames of sparks in the area.

Remove the fuel strainer cup and the O-ring. Wash the removed parts in solvent, dry them thoroughly and reinstall them securely.

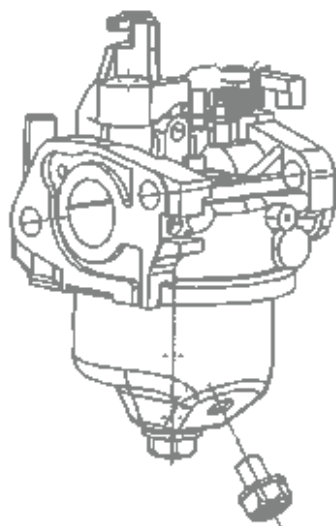

## Spark plug service

Recommended spark plug: F7RTC /F6RTC

To ensure proper engine operation, the spark plug must be properly gapped and free of deposits.

- 1) Remove the spark plug cap.

**WARNING!** If the engine has been running the muffler will be very hot. Be careful not to touch the muffler.

- 2) Visually inspect the spark plug. Discard it if the insulator is cracked or chipped.

- 3) Measure the plug gap with a feeler gauge. The gap should be 0.7-0.8mm (0.028-0.031 in), Correct as necessary by bending the side electrode.

- 4) Attach the plug washer, thread the plug in by hand to prevent cross-threading.

- 5) When mounting a new spark plug, you should screw 1/2 more thread with the wrench after the washer is compressed. If you are mounting an old one, you should only screw 1/8-1/4 more thread.

**CAUTION:** The spark plug must be securely tightened. An improperly tightened plug can become very hot and possibly damage the engine. Never use a spark plug with an improper heat range.

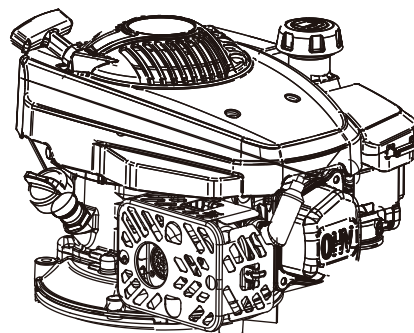
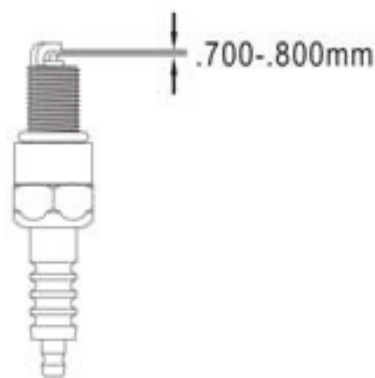

## ***TRANSPORTING AND STORAGE***

**WARNING!** When transporting the tiller, turn the fuel valve OFF and keep the tiller level to prevent fuel spillage. Fuel vapor or spilled fuel may be ignited.

Before storing the unit for an extended period, follow below steps.

**1 Be sure the storage area is free of excessive humidity and dust.**

**2 Drain the fuel.**

**WARNING!** Gasoline is highly flammable and explosive under certain conditions. Do not smoke or allow flames or sparks in the area.

- 1) With the fuel valve turned OFF, remove and empty the fuel strainer cup.
- 2) Turn the fuel valve ON and drain the gasoline in the fuel tank into a suitable container.
- 3) Replace the fuel strainer cup and tighten securely.
- 4) Drain the carburetor by loosening the drain knob. Drain the gasoline into a suitable container.

**3 Pull the starter grip until resistance is felt. Continue pulling until the notch on the starter puller aligns with the hole on the recoil starter.**

At this point, the intake and exhaust valves are closed and this will help to protect the engine from internal corrosion.

**4 Change engine oil.**

**5 Cover tiller with plastic sheet.**

Do not place the tiller with the handlebars on the ground. It will cause the oil entering the cylinder or the fuel spillage.

## **TROUBLESHOOTING**

### **Engine failure and troubleshooting**

Failure	Possible Causes	Solution
Can not be started	No enough fuel	Check fuel level in the fuel tank
	Fuel valve is OFF	Open the fuel valve
	Engine switch is OFF	Turn the engine switch ON
	Carburetor is blocked	Loosen the drain knob with the fuel valve ON. Fuel can flow out freely and then retighten drain knob.
	No spark from the spark plug	Remove and clean the spark plug

**WARNING!** If any fuel is spilled, make sure the surface is dry before testing the spark plug or starting the engine. Fuel vapor or spilled fuel may ignite.

### **Engine failure and troubleshooting**

Failure	Possible Causes	Solution
Clutch not working	Engine speed is low	Open throttle, increase engine speed
	Belt too long	Replace
	Spring failure	Replace
	Bearing inside gearbox failure	Replace
Sliding	Spring/Belt failure	Replace
Abnormal noise from gears	Bearing loosen	Replace
	Driven shaft deformed	Replace
	Gears wear out	Replace
Oil leakage	O type sealing failure	Replace
	Bolts loosen	Tighten

## ***SPECIFICATIONS***

ITEM		CONTENT
TILLER	Model	SPT150
	Dimension (LxWxH)	705x375x660mm
	G.W. (kg)	36
	Tilling scope (mm)	560
	Tilling depth (mm)	130
Noise	Guaranteed sound power level (dB(A))	93
ENGINE	Model	DV150
	Type	Single Cylinder, 4-stroke, OHV, air cooling
	Displacement (cm <sup>3</sup> )	150
	Rated power (kW/min <sup>-1</sup> )	2.6/3000
	Fuel tank capacity (L)	1.0
	Oil Capacity (L)	0.4

# EC DECLARATION OF CONFORMITY

1. Product model: SPT150
2. Name and address of the manufacturer or his authorised representative:



SGS Engineering (UK) Ltd  
Unit 1 West Side Park, Raynesway, Derby, DE21 7AZ  
Telephone: +44 (0)1332 576 850

3. This declaration of conformity is issued under the sole responsibility of the manufacturer.
4. Object of the declaration:

Equipment: 56cm Gasoline Tiller  
Brand name: SGS

5. The object of the declaration described above is in conformity with the relevant statutory requirements:

Machinery Directive (2006/42/EC)  
Electromagnetic Compatibility Directive (2014/30/EU)  
Noise Emission Directive by equipment for use outdoors (2000/14/EC + 2005/88/EC)  
Assessment Procedure: 2000/14/EC, amended by 2005/88/EC- Annex VI  
- Measured Sound Power Level - LwA 91.23 dB(A)  
- Guarantee Sound Power Level - LwA 93 dB(A)

6. References to the relevant designated standards used or references to the other technical specifications in relation to which conformity is declared:

EN ISO 5395-1:2013  
EN ISO 5395-2:2013/A2:2017  
EN ISO 14982:2009

7. The person authorized to compile the technical file:

Name: Neil Sansom  
Address: SGS Engineering (UK) Ltd, Unit 1 West Side Park, Raynesway, Derby, DE21 7AZ

Signed for and on behalf of:

Authorised Representative

A handwritten signature in black ink, appearing to read 'Neil Sansom', written over a horizontal line.

Neil Sansom, CEO  
Date: 10/09/2025

